



ENHANCEMENT OF POWER QUALITY USING SELF SUPPORTED DVR

1. KALYADAPU RAJASHEKAR 2. RAMAVATH SHANKAR NAIK

1.Pg Scholar, Department of EEE, SLC's Institute of Engineering and Technology,Hyderabad.

2.Associate Professor& HOD, Department Of EEE, SLC's Institute of Engineering and Technology, Hyderabad

Abstract: In this project, different voltage injection schemes for dynamic voltage restorers (DVRs) are analyzed with particular focus on a new method used to minimize the rating of the voltage source converter (VSC) used in DVR. One of the best solutions to improve power quality is the dynamic voltage restorer (DVR). DVR is a kind of custom power devices that can inject active/reactive power to the power grids. This can protect loads from disturbances such as sag and swell. Usually DVR installed between sensitive loads feeder and source in distribution system. Its features include lower cost, smaller size, and its fast dynamic response to the disturbance a new control technique is proposed to control the capacitor-supported DVR. The control of a DVR is demonstrated with a reduced-rating VSC. The reference load voltage is estimated using the unit vectors. The synchronous reference frame theory is used for the conversion of voltages from rotating vectors to the stationary frame. The compensation of the voltage sag, swell, and harmonics is demonstrated using a reduced-rating DVR. This project presents the simulation of DVR system using MATLAB/SIMULINK.

Keywords: *Dynamic Voltage Restorer (DVR), Power Quality, Unit Vector, Voltage Harmonics, Voltage Sag, Voltage Swell.*

I. INTRODUCTION

Dynamic voltage restores (DVRs) are now becoming more established in industry to reduce the impact of voltage dips on sensitive loads. A voltage dip is commonly defined as any low voltage drop event between 10% and 90% of the nominal RMS voltage, lasting between 0.5 cycles and 1 min. In comparison with interruptions, voltage dips affect a large number of customers and for some cases may cause extremely serious problems. Voltage dips are one of the most occurring power quality problems. They occur more often and cause severe problems and economical losses. There are different ways to mitigate voltage dips, swells and interruptions in transmission and distribution systems. At present, a wide range of very flexible controllers which capitalize on newly available power electronics components are emerging for custom power applications. Among these, the distribution static compensator and the dynamic voltage restorer are the most effective devices; both of them based on the voltage source converter (SVC) principle. Fig.1 shows a typical DVR series connected topology. The DVR essentially consists of a series inverter (VSI), inverter output filter and an energy storage device connected to the DC link. The basic operation principle of the DVR is to inject an appropriate voltage in series with the supply through injection transformer whenever voltage sag or voltage swell is detected. In addition to voltage sags and swells compensation, DVR can also perform other tasks such as harmonic compensation and Power Factor correction. Compared to the other Custom Power devices, the DVR

clearly provides the best economic solution for its size and capabilities. This research introduced Dynamic Voltage Restorer (DVR) and its voltage compensation methods. At the end, simulation results using MATLAB were illustrated and discussed.

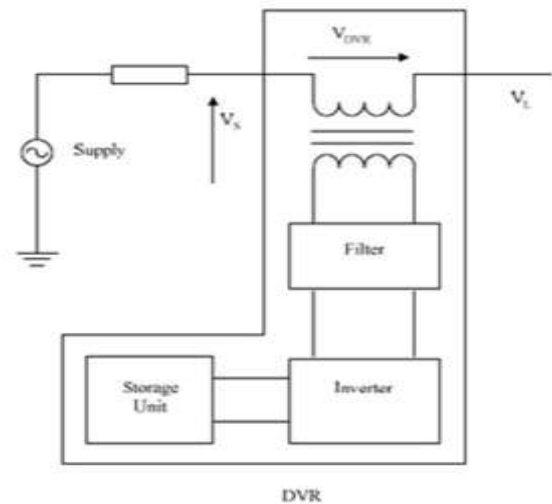

Fig.1. DVR Series Connected Topology.

II. DYNAMIC VOLTAGE RESTORER (DVR)

Among the different power quality problems voltage sags, swells and harmonics creates the losses and tripping at the consumer side. In order to overcome the problems the concept of custom power devices emerged into the

distributions system. One of the most efficient and effective modern custom power devices is DVR. A DVR is a series connected solid state device that injects the voltage into the system to order to regulate the load terminal voltage. The primary function is to boost up the load side voltage rapidly during voltage sag or swell in order to avoid any disruption on load side voltage. With various topologies and various controlling schemes DVR is used to improve power quality problems, other than that DVR having special features as line voltage harmonic compensation, reduction of transients in voltage and fault current limitations.

A. Components of DVR

There are five important components of DVR as shown in Fig.2

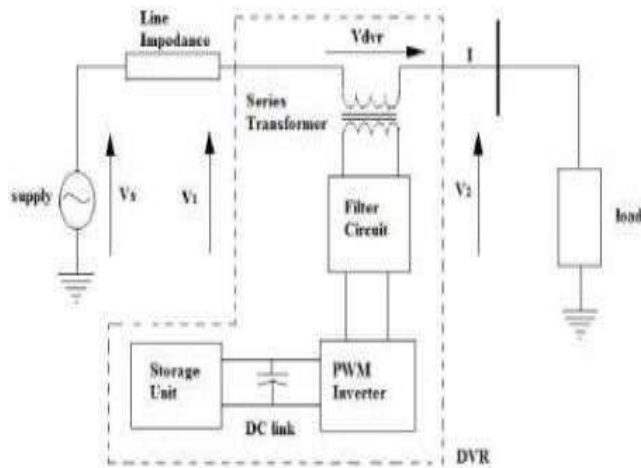

Fig.2. Components of DVR.

1. Voltage source PWM Inverter: It is a power electronic system consisting of switching devices like MOSFET (Metal Oxide Semiconductor Field Effect Transistor), GTO (Gate Turn-Off Thyristor), IGBT (Insulated Gate Bipolar Transistors) and IGCT (Insulated Gate Commutated Thyristors), which can generate sinusoidal voltage at any required frequency, magnitude and phase angle. The VSC is used to either completely replace the supply voltage or to the inject the missing voltage which is the difference between the nominal voltage and the actual voltage. Usually VSC is not only used for mitigation of voltages but also for the power quality issues like flickers and harmonics.

2. Injection Transformer: It is used to connect the DVR circuit to the distribution system. Transformer transforms and couples the injected voltages generated by the VSC to the incoming supply voltage. Low voltage windings are connected to the DVR circuit and High voltage windings are connected to the distribution system at the Point of Common Coupling (PCC). In this work three single-phase transformer or three-phase transformer may be used.

3. Storage Unit: It supplies the required energy to the VSC via DC link for the generation of injected voltage in case of sags or swells.

4. DC charging Circuit: The DC charging circuit performs the following tasks. Firstly, it charges the energy source after the compensation of sag/swell event. And secondly, it maintains the DC link voltage at the nominal value.

5. Filter: It is used to maintain the low level harmonic content generated by the VSC to the acceptable level.

B. Operation of DVR

The schematic diagram of DVR is as shown in Fig.3. Three phase source voltages V_{sa} , V_{sb} and V_{sc} are connected to the three-phase critical load through series impedance Z_a , Z_b and Z_c and an injection transformer in each phase. Because of the power quality problems the source voltages become terminal voltages as V_{ta} , V_{tb} and V_{tc} . To get undistorted and balanced load voltages V_{La} , V_{Lb} and V_{Lc} , DVR injects compensating voltages V_{Ca} , V_{Cb} and V_{Cc} through the injection transformer. DVR is used three leg VSC with IGBTs along with a DC capacitor or a Battery energy storage system. A ripple filter (L_r , C_r) is used to filter out the switching ripple in the injected voltage by the VSC.

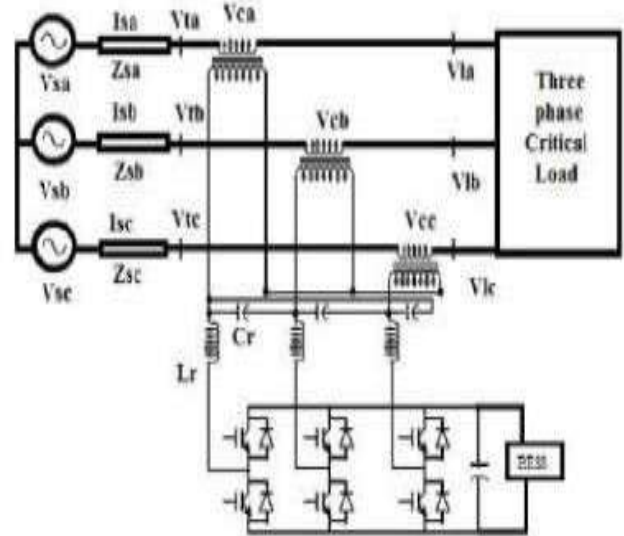

Fig.3. Operation of DVR.

The operation of DVR for the compensation of sag and swell in the supply voltage is shown in figure 3 with the help of the phasor diagrams. Before sag the load voltages is indicated as V_L (pre-sag) and current as I_{sa} in case of both sag and swell operation. After the sag event, the terminal voltage (V_{ta}) is gets lowered in magnitude and lags the pre-sag voltage by some angle. When DVR injects compensating voltage V_{Ca} to maintain the load voltage V_L at the rated magnitude V_{Ca} is splitted into two components V_{Cad} and V_{Caq} . The voltage in-phase with the current V_{Cad} is required to regulate the DC bus voltage and also to meet the power losses in the VSC of the DVR and an injection transformer. The voltage in quadrature with the current V_{Caq} is required to regulate the load voltage V_L at constant magnitude. During Swell event, the injected voltage V_{Ca} is such that the load voltage lies on the locus of the circle as shown Fig.4b.

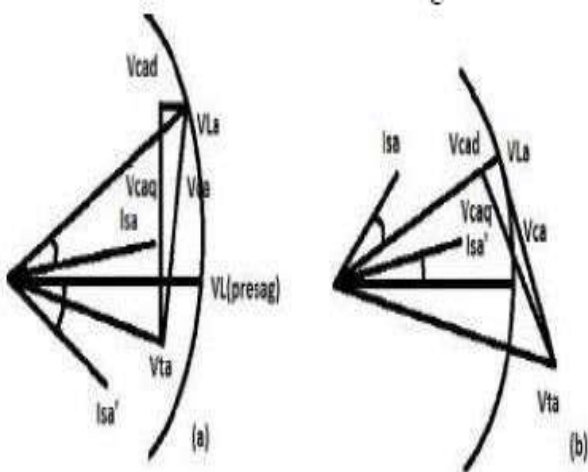

Fig.4. Phasor Diagram, 4(a) Voltage Sag, 4(b) Voltage Swell.

C. Voltage Injection Schemes

Depending upon the phase angle and magnitude differences in the terminal voltage DVR injects the voltage to maintain the balanced load voltages. Injection schemes depend on several limiting factors such as DVR power rating, load conditions and voltage sag type. Therefore the control strategies to be applied depend upon the load characteristics. There are four different methods of DVR voltage injection schemes.

Scheme-1: Pre-Sag Compensation Method: It tracks the supply voltage continuously and if it detects any disturbance in that voltage it will inject the difference voltage between the sag or voltage at the PCC and the ideal pre-fault condition. In this way, the load voltage can be restored back to the pre-fault condition. Compensation of voltage sags in both phase angle and an amplitude sensitive load has to be achieved by the pre-sag compensation method as shown in Fig.5. In this method, the active power injected by the DVR cannot be controlled and it is determined by external conditions such as the type of faults and the loading conditions.

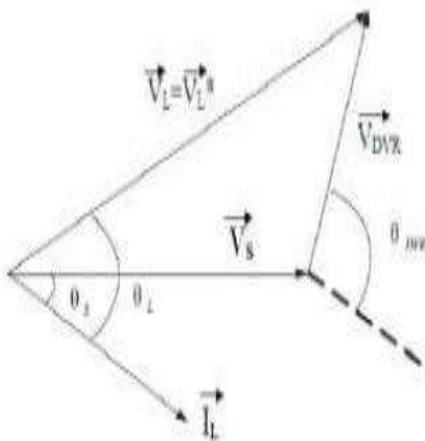

Fig.5. Single phase vector diagram of Pre-Sag compensation method.

Scheme-2: In-Phase Compensation Method: It is the most straight forward method. In this method the injected voltage is in-phase with the PCC voltage regardless of the load current and pre-fault voltage. The phase angles of the pre-sag and load voltage are different but the attention is placed on maintaining a constant voltage magnitude on the load. One of the advantages of this method is that the amplitude of DVR injection voltage is minimum for certain voltage sag in comparison with other schemes. In practical applications the loads which are not sensitive to phase angle jumps are applicable for this method. Fig.6 is single-phase vector diagram.

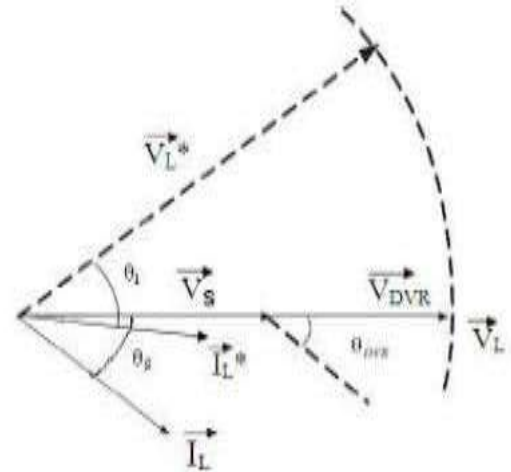

Fig.6. Single phase vector diagram of In-Phase compensation method

Scheme-3: In-Phase Advance Compensation Method: In this compensation method the real power used by DVR is minimized by decreasing the power angle between the sag voltage and the load current. In the above two cases active power is injected into the system by the DVR during disturbances. Moreover, the active power supplied is limit to the stored energy in the DC link and this part is most expensive part in the system. The minimization of injected energy is achieved by making the injection voltage phasor perpendicular to the load current phasor. In this method the values of load current and voltage are fixed in the system so one can change only the phase of the sag voltage. This method is suitable for limited sag ranges. As shown in Fig.7.

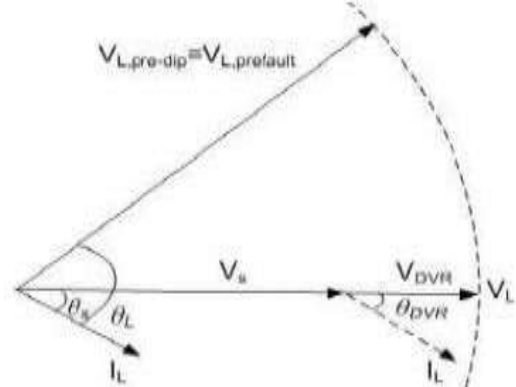

Fig.7. Single phase vector diagram of In-phase advance compensation method.

Scheme-4: Minimum Energy Injection Method: Generally voltage magnitudes between 90-110% of the nominal voltage and phase angle variations between 5-10% of the normal state will not disturb the operation characteristics of loads. This compensation method will maintain the load voltage within the tolerance area with small change of voltage magnitudes as shown in Fig.8.

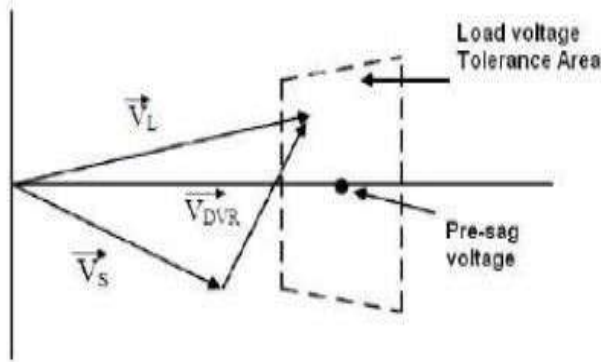

Fig.8. Single phase vector diagram of Minimum energy compensation method.

III. SIMULATION CIRCUIT RESULTS

In order to show the performance of the DVR in voltage sags and swells mitigation, a simple distribution network was simulated using MATLAB (Fig.9) and its final results. A DVR was connected to the system through a series transformer with a capability to insert a maximum voltage of 50% of the phase to ground system nominal voltage. In this simulation the In-Phase Compensation (IPC) method was used. The load considered in the study is a 5.5 MVA capacity with 0.92 p.f, lagging. Voltage sags: A case of Three-phase voltage sag was simulated and the results are shown in Fig.10a

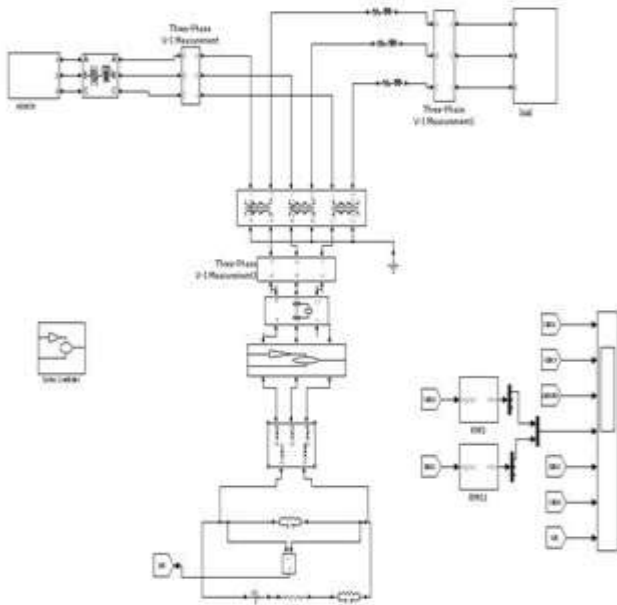

Fig.9. matlab/simulink diagram of proposed DVR system

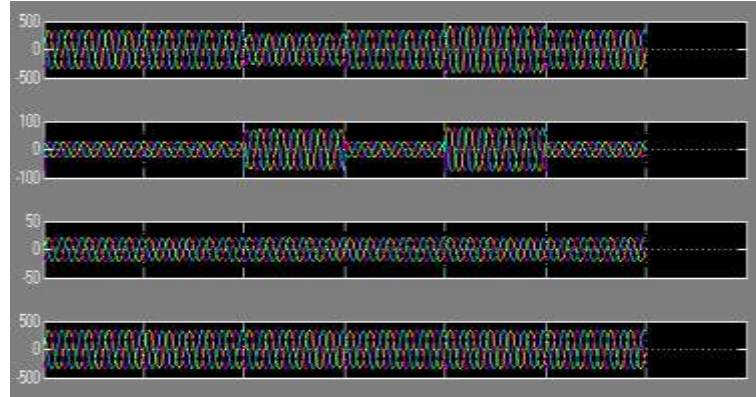

Fig. 10. Dynamic performance of DVR with in-phase injection during voltage sag and swell applied to critical load.

The compensation of harmonics in the supply voltages is demonstrated in Fig.10. At 0.2 s, the supply voltage is distorted and continued for five cycles. The load voltage is maintained sinusoidal by injecting proper compensation voltage by the DVR. The total harmonics distortions (THDs) of the voltage at the PCC, supply current, And load voltage is shown in Figs., respectively.

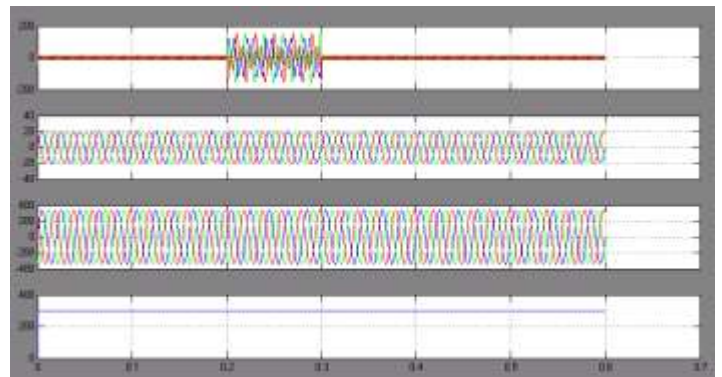

Fig.11. Dynamic performance of DVR during harmonics in supply voltage applied to critical load

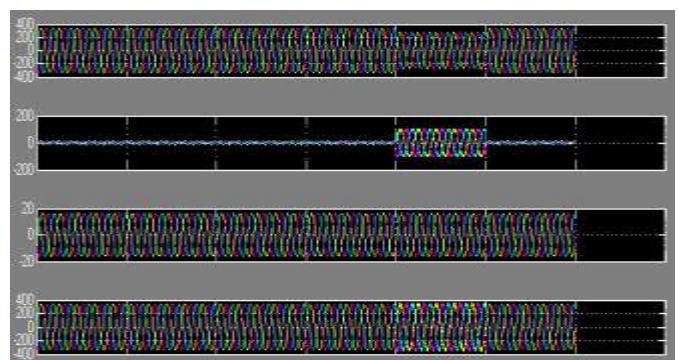

Fig.12. Dynamic performance of the capacitor-supported DVR during (a) voltage sag and (b) voltage swell applied to critical load.

IV.CONCLUSION

In this work the operation of DVR with different voltage injections method are explained using SRF Theory. For different types of power quality issues control schemes varies. A new control technique is adopted to reduce the rating of Voltage Source Converter. During in-phase voltage injection scheme the rating of VSC is minimized, but affects its cost on DC voltage source. Self supported DVR is widely used as a consequence of modest cost with fewer components for any type of Power quality problems. Simulation results demonstrate about DVR with different control schemes and successfully protect the sensitive loads without any power quality issues.

V.REFERENCES

- [1] Pychadathil Jayaprakash, Member, IEEE, Bhim Singh, Fellow, IEEE, D. P. Kothari, Fellow, IEEE, Ambrish Chandra, Senior Member, IEEE, and Kamal Al-Haddad, Fellow, IEEE, —Control of Reduced-Rating Dynamic Voltage Restorer With a Battery Energy Storage System, IEEE Transactions on Industry Applications, Vol. 50, No. 2, March/April 2014.
- [2] M. H. J. Bollen, Understanding Power Quality Problems—Voltage Sags and Interruptions. New York, NY, USA: IEEE Press, 2000.
- [3] A. Ghosh and G. Ledwich, Power Quality Enhancement Using Custom Power Devices. London, U.K.: Kluwer, 2002.
- [4] M. H. J. Bollen and I. Gu, Signal Processing of Power Quality Disturbances. Hoboken, NJ, USA: Wiley-IEEE Press, 2006.
- [5] R. C. Dugan, M. F. McGranaghan, and H. W. Beaty, Electric Power Systems Quality, 2nd ed. New York, NY, USA: McGraw-Hill, 2006.
- [6] A. Moreno-Munoz, Power Quality: Mitigation Technologies in a Distributed Environment. London, U.K.: Springer-Verlag, 2007.
- [7] K. R. Padiyar, FACTS Controllers in Transmission and Distribution. New Delhi, India: New Age Int., 2007.
- [8] IEEE Recommended Practices and Recommendations for Harmonics Control in Electric Power Systems, IEEE Std. 519, 1992.
- [9] V. B. Bhavraju and P. N. Enjeti, —An active line conditioner to balance voltages in a three phase system, IEEE Trans. Ind. Appl., vol. 32, no. 2, pp. 287–292, Mar./Apr. 1996.
- [10] S. Middlekauff and E. Collins, —System and customer impact, IEEE Trans. Power Del., vol. 13, no. 1, pp. 278–282, Jan. 1998.
- [11] M. Vilathgamuwa, R. Perera, S. Choi, and K. Tseng, —Control of energy optimized dynamic voltage restorer, in Proc. IEEE IECON, 1999, vol. 2, pp. 873–878.
- [12] J. G. Nielsen, F. Blaabjerg, and N.Mohan, —Control strategies for dynamic voltage restorer compensating voltage sags with phase jump, in Proc. IEEE APEC, 2001, vol. 2, pp. 1267–1273.

AUTHOR'S PROFILE:



KALYADAPU

RAJASHEKAR received the B.Tech degree in Electrical & Electronics Engineering from Joginpallybasker engineering college in 2015 from JNTU, Hyderabad, Telangana, India and He is pursuing M.Tech in Electrical Power System(EPS) as specialization in the Department of Electrical & Electronics Engineering, SLC's Institute of Engineering and Technology, Affiliated to JNTU Hyderabad, Telangana, India. His research area of interests is Power system operation and control, Power quality improvement.

E-mail id: rajashekar.eee204@gmail.com



Ramavath Shankar Naik

received the B.Tech degree in Electrical Engineering from Vignan's Engineering College, Vadlamudi, Guntur, India, in 2006. He Completed M.E in Electrical Engineering with Power system Automation as specialization in the Department of Electrical Engineering, Andhra University College of Engineering (Autonomous), Visakhapatnam, He is currently an Associate Professor with the Department of Electrical & Electronic Engineering at SLC College Jntu University, Hyderabad, Telangana, India. His area of interest lies in Power system operation and control, optimal operation of power systems, and FACTS.

E-mail id: shankar02234@gmail.com